

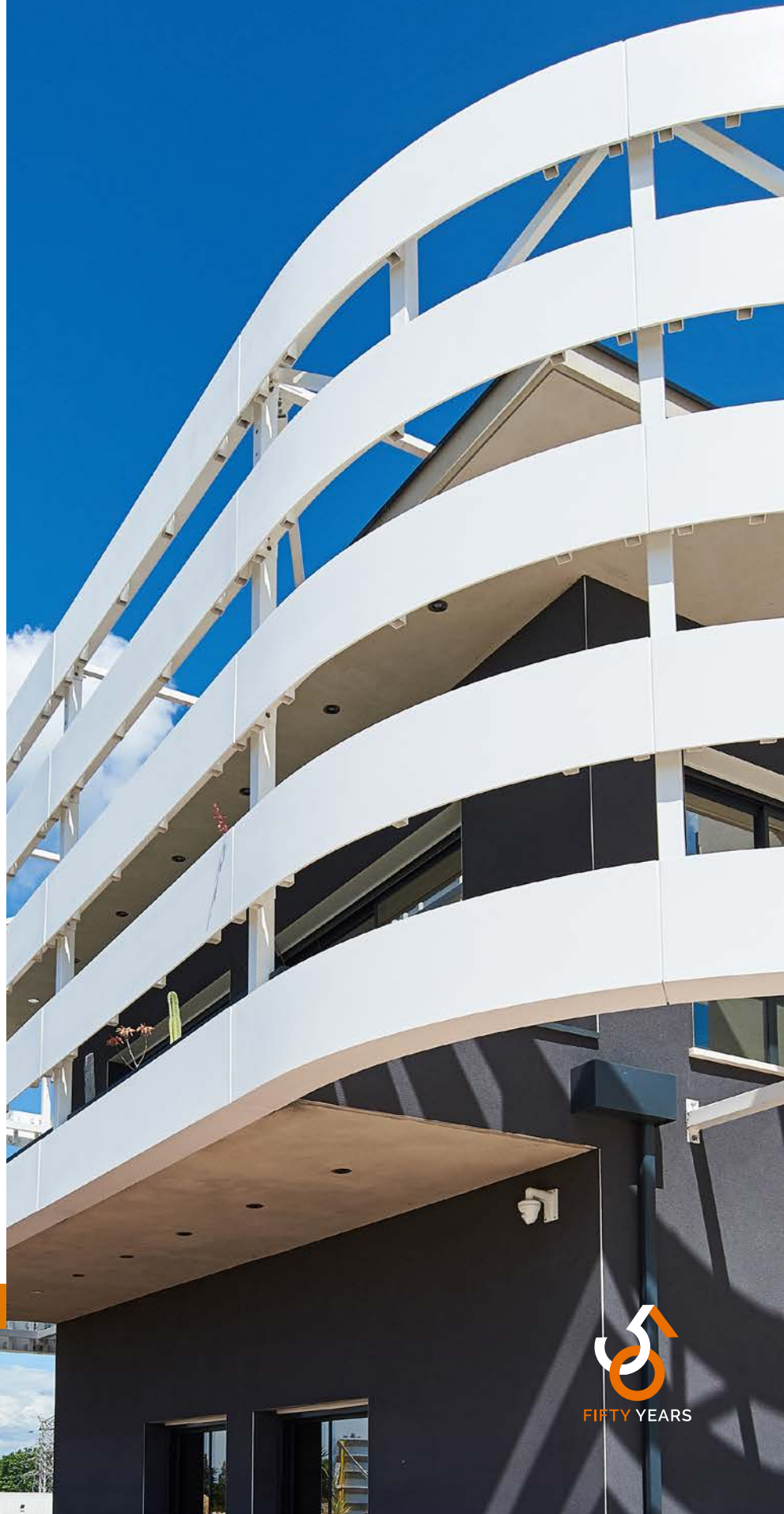

2 0 2 0
ENGLISH

**FACADE
WHITE BOOK**

WIDE MATERIAL
FOR WIDE IDEAS



AVONITE® IS A SOLID SURFACE MATERIAL COMPOSED OF 63% ALUMINA TRIHYDRATE, 35% ACRYLIC AND 2% PIGMENTS AND BINDERS. IT IS PRODUCED AT THE ARISTECH SURFACES LLC PLANT, IN FLORENCE (KY), USA, ON THE MOST FLEXIBLE AND SCALABLE PRODUCTION LINES IN THE WORLD.

The design properties of the AVONITE® facade panels, its adapted offering and its performance, make it a material of choice for any type of ventilated facade.

Cover:

Location: Béziers, France

Photographer: Hugo Da Costa

Fabricator: LCCA

Architect: Olivier Marty

AVONITE® Super White 8026

SUMMARY

THE BENEFITS OF A VENTILATED FACADE	4
AVONITE® ON FACADES	5
METEOROLOGICAL RESISTANCE	5
VERSATILITY	5
EXPERTISE	5
RELIABLE CLADDING MATERIAL AND EASY MAINTENANCE	5
OUR RIGHT SIZE PROGRAMME	6
DESIGN	7
THERMOFORMING	8
VARIETY OF TYPES OF JOINTS	9
A PERFECT COMBINATION WITH OTHER MATERIALS	9
FIXING SYSTEM	10
INSTALLATION	11
SINGULAR POINTS	12
PERFORMANCES	13
COLOURS	14
WARRANTY	15



THE BENEFITS OF A VENTILATED FACADE

- **CONTRIBUTES** to the insulation and the thermic regulation of a building.
- **PROTECTS** the indoor spaces from solar gain.
- **CONTRIBUTES** to the walls' acoustic properties.
- **PROVIDES** decorative finish to the facade.

AVONITE® ON FACADES

METEOROLOGICAL RESISTANCE

AVONITE® is resistant to the effect of frost on the facade surface and joint details (source: ETA-17/0094).

AVONITE® panels are also resistant to humidity and are not affected by exposure to a humid environment*.

Aristech Surfaces LLC recommends a selection of 7 highly UV-resistant colours, that give a performance of < 5 units ΔE CIE lab.

**The exposure to salt water must however be indirect, in order not to deteriorate the material.*

VERSATILITY

The compatibility of AVONITE® facade panels with any insulation system, substrate and load bearing profile, makes it a particularly versatile facade surface, which can be used on a new building, as well as in a refurbishment project.

RELIABLE CLADDING MATERIAL AND EASY MAINTENANCE

To keep an impeccable appearance, no specific maintenance of the facade is necessary on a daily basis. The facade panels may be cleaned with a high-pressure water cleaner.

EXPERTISE

Because the fabrication and installation techniques for facades require specific skills and experience, AVONITE® surrounds itself with the best partners, in order to design your facade projects, from the smallest to the most ambitious building.

Since the material is homogeneous through its thickness, the AVONITE® facade panels can also be sanded, in case of graffiti or light damage.



OUR RIGHT SIZE PROGRAMME



OUR 18 STANDARD FORMATS

AVONITE®'s **RIGHT SIZE** Programme refers to 18 formats of sheets **WITH NO SURCHARGES PER M²**.

- Thickness: 12 mm*.
- Lengths: 2438 mm | 3048 mm | 3658 mm.
- Widths: 762 mm | 914 mm | 1067 mm | 1219 mm | 1372 mm | 1524 mm.

* The **RIGHT SIZE** Programme applies to any standard AVONITE Surfaces® colour in 12 mm thickness, with the exception of 8064 Ice White, 8298 Ice Blue, 8901 Altitude, 8903 Torrent, 8904 Morning Mist, 8905 Summit, 8908 Calm and 8909 Unwind. Please contact your local distributor to get the list. Lead time and minimum order quantity will apply.

DO YOU HAVE A SMALL PROJECT THAT DOES NOT MEET THE MINIMUM ORDER?

We have not forgotten you. A large selection of **RIGHT SIZE** formats is available in our European stock, in our most popular colour: **SNOWFALL**.

USING THE RIGHT FORMAT OF SHEETS IS THE RIGHT CHOICE FOR CONSUMING LESS.

The use of large sheets reduces the number of joints required. Fewer joints mean less adhesive, less work and therefore less cost to the end user.

The choice of an optimal format reduces scrap. Less scrap means taking a step to help the environment.



WIDER SHEETS = TIME SAVED = BIG SAVINGS

DESIGN

WHAT MAKES THE DIFFERENCE WITH AVONITE® FACADE PANELS ARE THEIR OUTSTANDING DESIGN PROPERTIES.



Backlighting pattern using an indirect lighting.

Designer: Dipl. Ing. Walter Ebeling
BDB n3 architecture, Hagen

Fabricator: Rosskopf + Partner AG

Photo: Knoepfel GmbH

BACKLIGHTING

AVONITE® can be backlit in different ways.

From a diffuse projection to a "pixels" look, from a total facade look to punctual milled patterns, everything is possible with AVONITE®.

Direct lighting model with a LEDs rail,
for a pixelized effect.

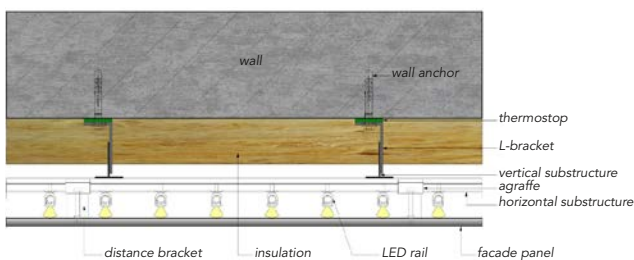

Direct lighting

Indirect lighting model with LEDs projected on
a reflective surface, for a diffuse lighting effect.

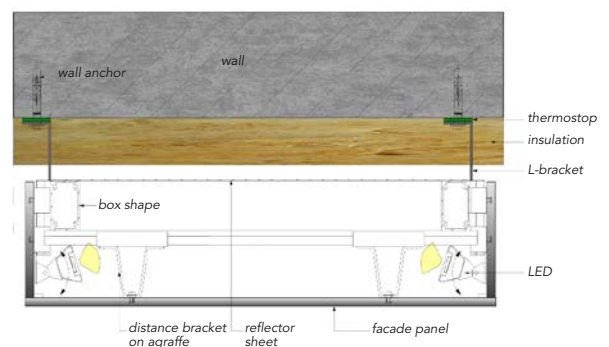

Indirect lighting

THERMOFORMING

WHAT IS MORE DAZZLING THAN AN ORGANIC SHAPED FACADE,
WITH ITS FLUID MOVEMENT?



Designer: Gensler Architects
Fabricator: Roskopf+Partner AG
Photo: Abdali Mall Company

THIS IS ALSO POSSIBLE WITH
AVONITE® FACADE PANELS!

On punctual elements, in order to give a dynamic impulse to a flat facade, or in repeated details or with large curved surfaces, bespoke fixing systems can be realized with the assistance of our partners.

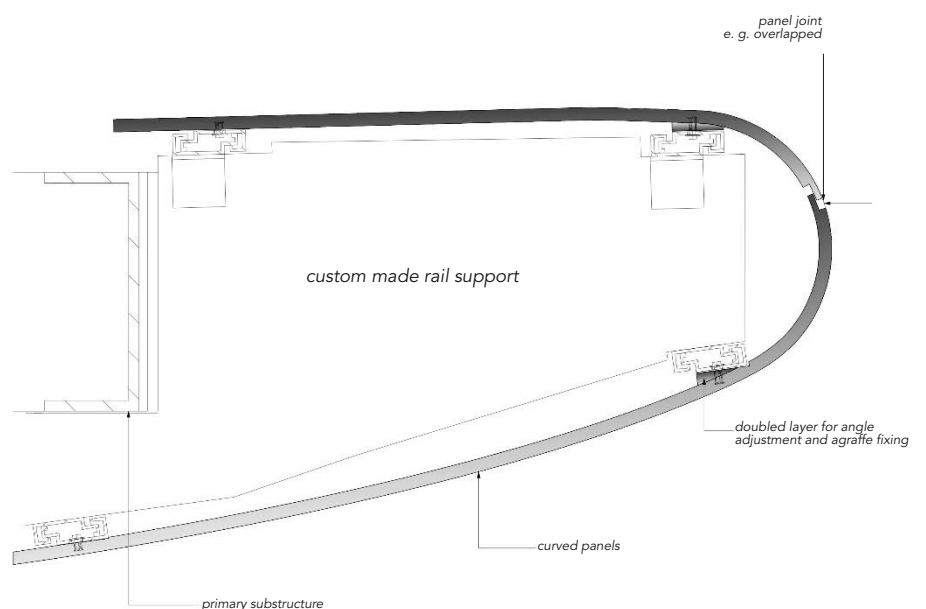

Curved panel. Bull-nose ending of a canopy.

VARIETY OF TYPES OF JOINTS

Location: Béziers, France
 Photographer: Hugo Da Costa
 Fabricator: LCCA
 Architect: Olivier Marty

For varied designs, different types of joints are possible. Some of them show the supporting structure, others hide it completely, but always with one constraint: space for the material to expand and to contract, according to weather conditions.



overlapping panels

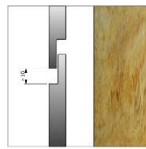

open gap

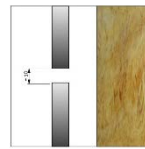

sealing on the backside

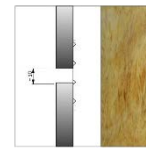

Panel joints

Designer: Laurence Sonck
 Fabricator: M2 Ibiza Construct SL
 Photo: Arsen Mikitov



A PERFECT COMBINATION WITH OTHER MATERIALS

AVONITE® perfectly matches with other more traditional materials, such as wood or natural stone, making it an ideal partner to deliver punctual details on balconies, window frames or at the entrance of a building.



Designer: Laurence Sonck
 Fabricator: M2 Ibiza Construct SL
 Photo: Arsen Mikitov

FIXING SYSTEM

THE RECOMMENDED FIXING SYSTEM TO HANG AVONITE® FACADE PANELS IS ETA CERTIFIED AND ALLOWS AN INVISIBLE FIXING. THAT'S ANOTHER ADVANTAGE FOR THE CONCEPTION OF A DESIGN FACADE! WITH AN EXTRA BENEFIT: PROTECTED BY THE PANELS, THE FIXING SYSTEM LASTS LONGER.

This system entails 2 main elements: the KEIL inserts and the load bearing profiles.

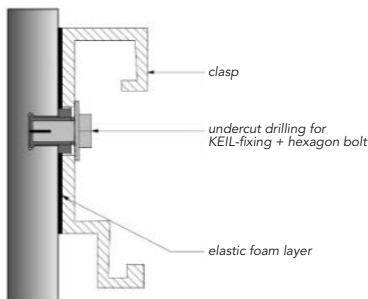

KEIL fixing

KEIL UNDERCUT ANCHOR

The KEIL undercut anchor KH for facade panels made with AVONITE® Acrylic Solid Surfaces is a special anchor made of stainless steel, consisting of a crosswise slotted anchor sleeve with an M6 internal thread, at the upper edge of which a hexagon is formed to it and a respective hexagon bolt with an integrated tooth lock washer. The anchor is put into an undercut drill hole and by driving-in the screw it is placed form-fitted and deformation-controlled.

The facade panels with rear fixing by the anchor may only be used for rear ventilated front curtain walls.

LOAD BEARING PROFILE

The installation frame is relatively common. We recommend standard BWM profiles for the realisation of a flat facade and bespoke profiles for a thermoformed facade (for this point, please refer to the section: **THERMOFORMING**, p. 8).

The vertical profiles are fixed on the load bearing brick or concrete wall, through the insulation layer, whereas the horizontal profiles are fixed on top of them. Agraffes are fixed with the KEIL anchors on the AVONITE® facade panels. With these, the panels can be adjusted and hanged to the horizontal profiles.

Calculations are needed to determine the optimum position of each KEIL insert. For this, please refer to the section: **INSTALLATION**, p. 11.

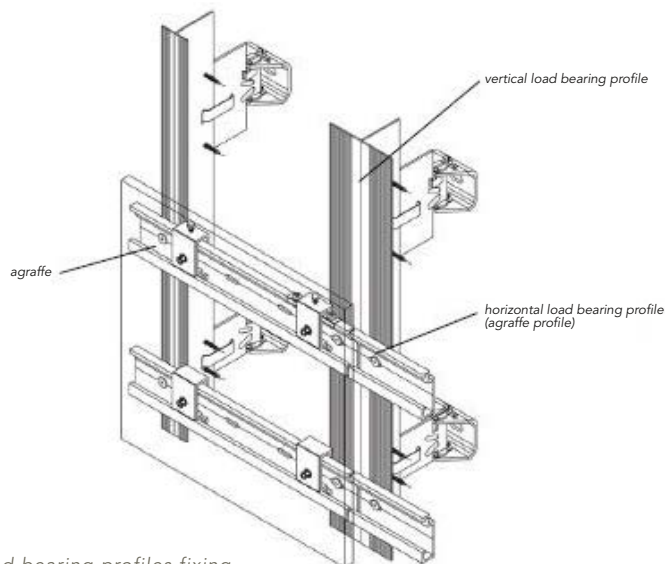

Load bearing profiles fixing

INSTALLATION

Prior to installation, facade sheets will require a light finish sanding step to obtain an even appearance. Sheets should be trimmed to the desired length, width, and edge profile.

Each facade panel is fixed with at least four anchors in rectangular arrangement via single agraffes to the substructure; the substructure is constructed such that the facade panels are fixed technically strain-free via skids (loose bearings) and one fixed bearing.

The facade panels are arranged in a reclined or upright position, they also may be fixed at facade soffits.

Two fixing points of the facade panel are designed such that they are able to carry the dead load of the facade panel.

The load-bearing profiles are arranged symmetrically. The arrangement of the agraffes ensures a symmetric introduction of the load into the substructure.

When using agraffes on horizontal load-bearing profiles the fixing points of a facade panel situated horizontally at the same height are fastened in each case to the same load-bearing profile.

The facade panels are neither used to transmit impact loads nor for guard rail.

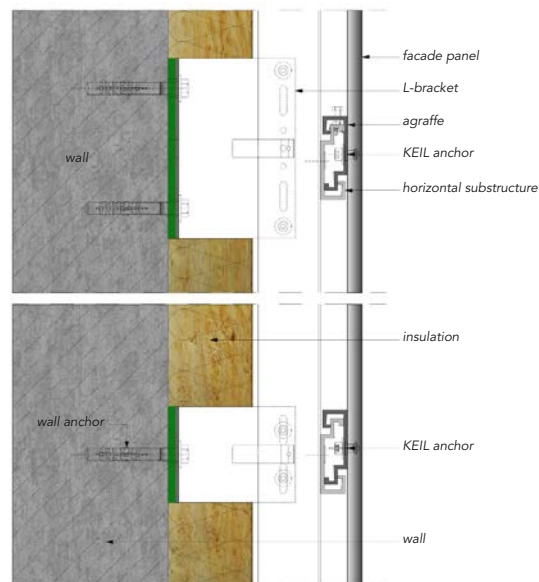

Vertical section

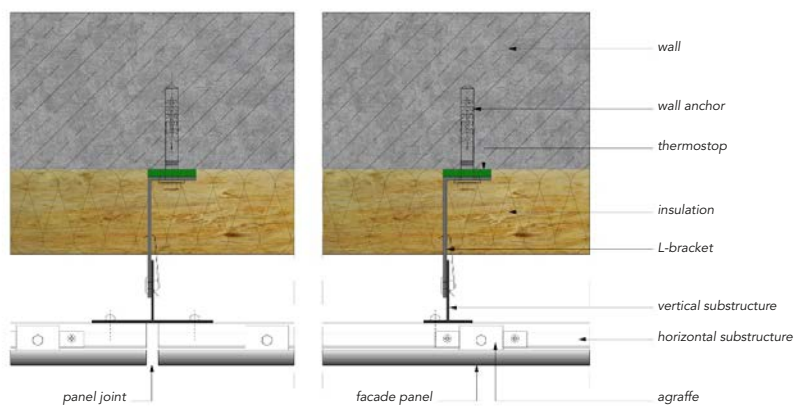

Horizontal section

SINGULAR POINTS

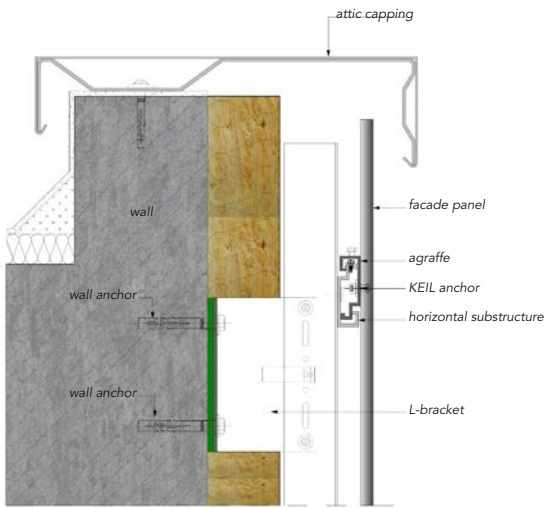

Attic edge

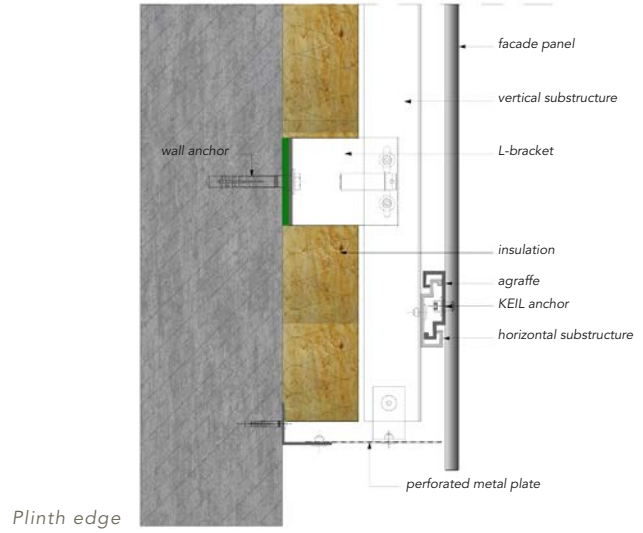

Plinth edge

OUTSIDE OPENINGS TREATMENTS

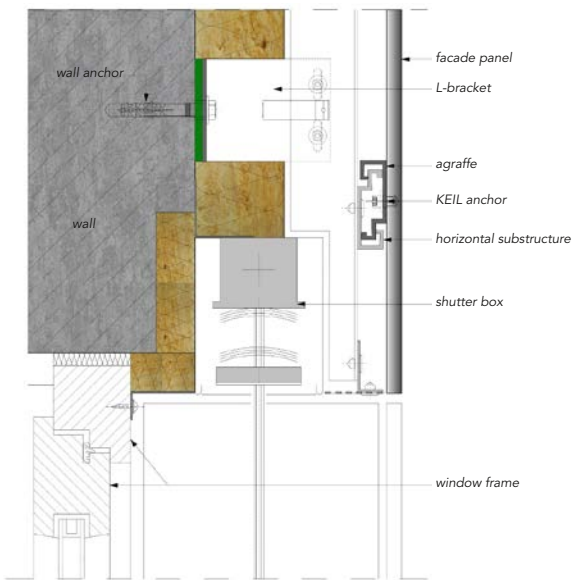

Shutter box

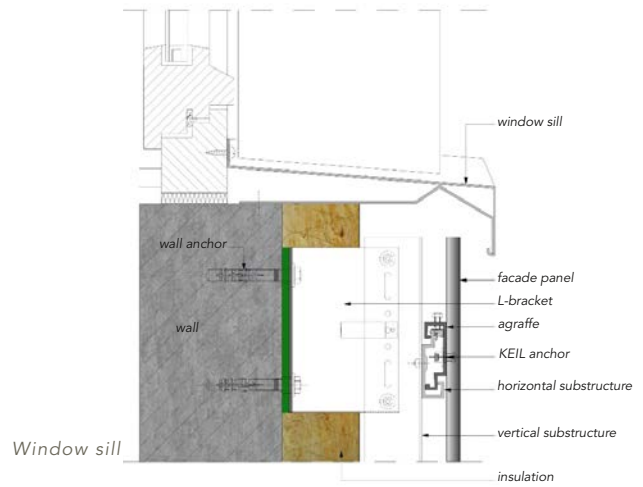

Window sill

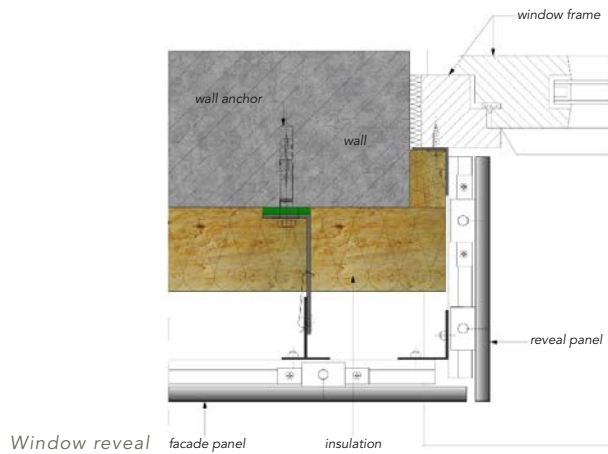

Window reveal

CORNERS TREATMENT

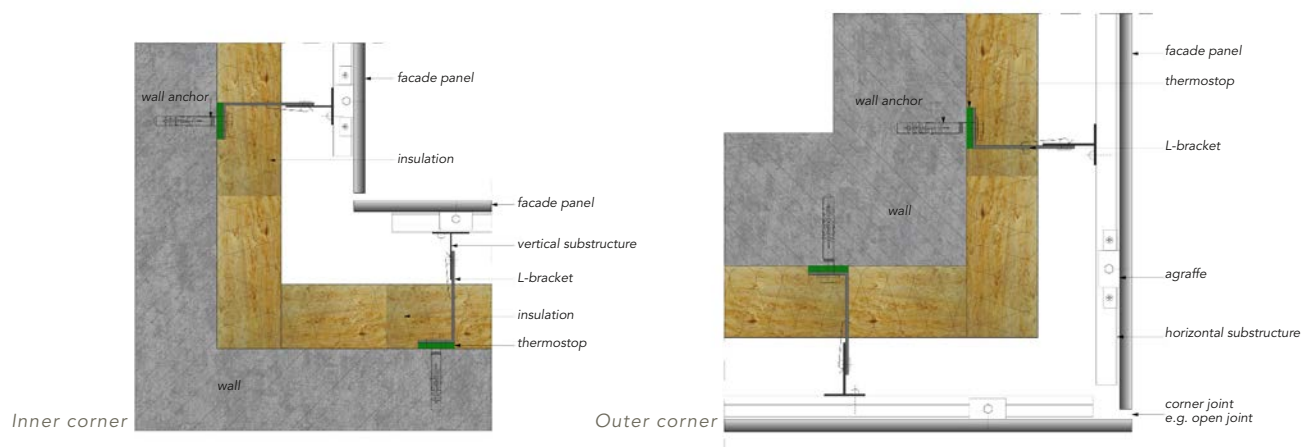

PERFORMANCES

Characteristic values of FACADE PANEL	Panel thickness	$h =$	mm	12
	Characteristic resistance to bending stress	$\sigma_{rk, 5\%} =$	N/mm ²	39,11
	Partial safety factor ⁽¹⁾	$\gamma_M =$		2,0
	Modulus of elasticity	$E =$	N/mm ²	8000
	Thermal coefficient	αT	1/°C	$3,76 * 10^{-5}$
	Density	$\gamma =$	g/cm ³	1,73
	Resistance to water		%	0,04
	Frost resistance			yes
Characteristic values of THE ANCHOR	Characteristic resistance to tension load ⁽²⁾	$N_{rk, 5\%} =$		2,12
	Characteristic resistance to shear ⁽²⁾	$V_{rk, 5\%} =$		5,42
	Setting depth	$h_s =$		7,0
	Edge distance ⁽³⁾	a_{rx} or $a_{ry} \geq$		100
	Spacing	a_x or $a_y \geq$		200 ⁽⁴⁾
	Partial safety factor	$\gamma_M =$		2,0

(1) In absence of other material regulations.

(2) In case of coincident stress of an anchor due to tension and shear load following equation shall be observed: $\frac{N_{Ed}}{N_{Rd}} + \frac{V_{Ed}}{V_{Rd}} \leq 1.0$

(3) For small fitted pieces, differential and fill-in pieces the edges distance and spacing shall be chosen constructively.

(4) The maximum of distance is governed by the load bearing capacity of the panel and determined through the static calculation.

FIRE RESISTANCE

DIN4102 Class B1, EN13501 class B-s1-do certified, the AVONITE® Solid Surface cladding can be used on any public or private building of less than 18 m in height.

When a better fire resistance is needed, AVONITE® can provide a NF P 92-501 Class M1 -certified formulation, available in white, in any dimension (please read the section: **OUR RIGHT SIZE PROGRAMME**, p. 6 to know more about the dimensions).

COLOURS



Standard panels' dimensions:
12 mm x W. 762 mm x L. 3657 mm.
For other dimensions, please
refer to our **RIGHT SIZE**
programme, p 6.

Among the wide AVONITE®
colour pallet, 7 colours have
been selected because of
their outdoor performances.
These colours are UV-resistant,
in the limit of 5 units ΔE CIE lab.

Architect: Pranlas-Descour

Fabricator: LCCA

Photographer: Antoine Guilhem-Ducl on



8010 Bone



8016 White



8024 Cr me



8026 Super White



8090 Snowfall



8106 Ivory



8256 Polaris

WARRANTY

LIMITED WARRANTY COMMERCIAL AND RESIDENTIAL EXTERIOR APPLICATIONS

Aristech Surfaces LLC ("Aristech") warrants for outdoor use to the original owner of AVONITE Surfaces® Acrylic Solid Surface for a period of ten years from the date of original purchase from Aristech that sheets made with colours 8016 White, 8026 Super White, 8090 Snowfall, and 8256 Polaris will be free from manufacturing defects, the colour will not fade or change more than 5 ΔE CIE lab units and gloss loss on a matte finish will not exceed 40%. Aristech warrants for outdoor use to the original owner of AVONITE Surfaces® Acrylic Solid Surface for a period of five years from the date of original purchase from Aristech that sheets made with colours 8010 Bone, 8024 Crème, and 8106 Ivory will be free from manufacturing defects, the colour will not fade or change more than 5 ΔE CIE lab units and gloss loss on a matte finish will not exceed 40%.

If any sheet of AVONITE Surfaces® Acrylic Solid Surface made with the colours listed above shows a change in colour of more than 5 ΔE CIE lab units or gloss loss in excess of 40% on a matte finish within five (5) or ten (10) years from the date of original purchase (depending upon the length of the applicable warranty term based upon the colour of the product), Aristech will, at its option and sole discretion, either provide a replacement sheet of AVONITE Surfaces® Acrylic Solid Surface or refund the original purchase price of the sheet.

This warranty applies only to AVONITE Surfaces® Acrylic Solid Surface sheets formed, maintained and installed in the manner recommended by Aristech in its facade white book and which have not been moved from their original place of installation. For coverage under this warranty, you must register on line at www.aristechsurfaces.com. The Company will assign a warranty

registration number. To obtain service under this warranty, write to the dealer/contractor from whom you purchased the product or alternatively write to Aristech Surfaces LLC at the address given below providing your name and address, warranty registration number, a description of the product involved, and the nature of the defect or failure. Refund or replacement shall not include any labour charges. A warranty registration number, purchase receipt or other acceptable proof of purchase will be required before any warranty claim can be considered.

Warranty claims should be sent to:
Aristech Surfaces LLC
Attn: Director of Quality
7350 Empire Drive
Florence, KY 41042

ARISTECH may ship (freight collect) to you products replaced under this Limited Warranty.

THIS LIMITED WARRANTY IS IN LIEU OF ALL OTHER WARRANTIES, AND ARISTECH EXPRESSLY DISCLAIMS ALL OTHER WARRANTIES, EXPRESS OR IMPLIED, INCLUDING WITHOUT LIMITATION ANY IMPLIED WARRANTY OF MERCHANTABILITY, FITNESS FOR A PARTICULAR PURPOSE (EVEN IF THE PURPOSE IS KNOWN TO ARISTECH), OR FROM COURSE OF DEALING OR TRADE USAGE. THIS LIMITED WARRANTY SETS FORTH THE INITIAL PURCHASER'S SOLE REMEDY IN CONNECTION WITH THE SALE OR USE OF PRODUCTS COVERED BY THIS LIMITED WARRANTY AND IN NO EVENT SHALL ARISTECH BE OTHERWISE LIABLE FOR ANY LOSS, DAMAGE OR INJURY OF ANY NATURE ARISING OUT OF THE SALE OR USE OF THE PRODUCTS DELIVERED HEREUNDER, WHETHER FOR NEGLIGENCE, BREACH OF CONTRACT OR UNDER ANY OTHER LEGAL OR EQUITABLE THEORY. ARISTECH SHALL

NOT BE LIABLE FOR ANY INDIRECT, SPECIAL OR CONSEQUENTIAL DAMAGES ARISING OUT OF THE SALE OR USE OF SUCH PRODUCTS, INCLUDING BUT NOT LIMITED TO LOST PROFITS, REVENUES, ANTICIPATED SALES, BUSINESS OPPORTUNITIES OR FOR INTERRUPTION OF BUSINESS. THIS WARRANTY IS NON-TRANSFERABLE. ARISTECH ASSUMES NO LIABILITY FOR IMPROPER FABRICATION AND/OR INSTALLATION.*

Exclusive jurisdiction for legal disputes relating to alleged breach of warranty or representation of any nature must be filed in either the state or federal courts located in Boone County, Kentucky. Kentucky law will govern all disputes or claims arising out of the sale, purchase or use of the solid surface products.

**Some states do not allow the exclusion or limitation of incidental or consequential damages, so the above limitation or exclusion may not apply to you. This warranty gives you specific legal rights, and you may also have other rights which may vary from state to state.*

European Head Office
ARISTECH SURFACES LLC
info.europe@aristechsurfaces.com

Global Headquarters
ARISTECH SURFACES LLC
7350 Empire Drive
Florence KY 41042
USA
T +1.800.354.9858

Find your closest distributor on
WWW.ARISTECHSURFACES.COM/AVONITE



AVONITE® is a registered trademark of Aristech Surfaces LLC. All other trademarks and product names are trademarks or registered trademarks of their respective rights owners. The information contained in this brochure is intended to be for information only and can be amended at any time without prior notification.
© 2020 Aristech Surfaces LLC. All rights reserved.